

Alloy Piping Products

- Pipe Dimensions
- Fitting Dimensions
- Butt-Weld Fitting Weights
- Tolerances

A World of **Solutions**
Visit www.alloypipingproducts.com





APP has become one of the world's leading manufacturers of pipe fittings. We have achieved that by doing two things: One, keeping our commitments to our customers, and two, investing heavily in our facilities, our people and our inventories.

Because our customers have given us the opportunity we needed, we have proven that an American company can meet the challenges of offshore competition and an increasingly tough marketplace.

At APP, our quality control systems are as demanding and as comprehensive as any in the industry. Likewise, no other American manufacturer can match the range of products we now offer.

With diverse inventories at warehouse locations across the country—and our ability to turn out quality orders—no other manufacturer anywhere can match our responsiveness.

You can depend on APP today, and you can count on us to continue to meet your needs in the future.

About Alloy Piping Products

Alloy Piping Products (APP) is a master distributor with manufacturing capabilities. We are a domestic manufacturer of butt-weld fittings in all grades of material, including carbon, low temp, high-yield, chrome, nickel and stainless alloys, selling through distribution only.

APP is also a master distributor for many other related product lines, pipe, flanges and forged fittings, both domestic and import. We operate a 385,000-square-foot manufacturing facility in Shreveport, La.

Along with manufacturing in New Brunswick, N.J. our manufacturing capabilities and considerable inventories of fittings and pipe enable us to realize greater efficiencies in the purchase of raw materials, reduce overall lead times and lower total installed costs. We operate multiple sales & distribution centers strategically located across the U.S. for fast, efficient service.

Domestic & Import

**Pipe - Fittings - Flanges - Forged Fittings
Carbon - Chrome - Stainless**

WPB - WPC - Low Temp - High Yield

WP11 - WP22 - WP5 - WP9 - WP91

304/L - 304H - 316/L - 316H - 317/L - 321/H - 347/H - Alloy 20 - Duplex

Toll Free: 800 551 8392



PIPE		
Welded Stainless Pipe	304/L ■ 316/L ■ 317/L ■ A20 ■ Duplex 2205	Size: 1/8" to 48" Schedules 10s thru True 80
Seamless Stainless Pipe	304/L ■ 304H ■ 316/L ■ 316H ■ 317/L ■ 321/H 347/H ■ A20 ■ Duplex 2205 ■ S32760 Super Duplex	Size: 1/4" to 20" All Schedules Available
Chrome, Carbon, and Low Temp Pipe	P11 / P22 / P5 / P9 / P91 / Grade 1/6 / A106B & B/C	Size: 1/2" to 36" Schedules STD thru XXH and heavier
Custom cutting to length also available for all alloys		
BUTT-WELD FITTINGS		
Stainless BW Fittings	304/L ■ 304H ■ 316/L ■ 316H ■ 317/L ■ 321/H 347/H ■ A20 ■ Duplex 2205	Sizes: 1/2" to 36" Schedules 10S thru XXH and heavier Seamless, Welded, Welded with X-Ray LR90 / LR45 / SR90 / Tee / Caps / Concs / Eccs / Return Bends / Crosses / Stub Ends
Chrome BW Fittings	WP11 / WP22 / WP5 / WP9 / WP91	Sizes: 1/2" to 24" Schedules STD to XXH and heavier Seamless LR90 / LR45 / SR90 / Tees / Caps / Concs / Eccs / Return Bends
Carbon BW Fittings	WPB / WPC / WPL6 / HY42 / HY46 / HY52 / HY65 / HY70	Sizes: 1/2" to 48" Schedules STD to XXH and heavier Seamless, Welded with X-Ray LR90 / LR45 / SR90 / Red90 / Tees / Caps / Concs / Eccs / Return Bends / Crosses / Swages
FLANGES		
Stainless Flanges	304/L ■ 316/L ■ 317/L ■ 321/H ■ 347/H ■ A20 ■ 2205 ■ 304/H	
Carbon, Chrome, Low Temp Flanges	F11 / F22 / F5 / F9 / A105 / LF2	Sizes: 1/2" to 36" 150# to 2500# RF / FF / WN / SO / Blind / S/W / Lap Joint / Long WN / Reducing / Orifice / High Hub / RTJ / Threaded
FORGED FITTINGS		
Forged Steel Fittings SW, Threaded	Carbon / Stainless / Chrome / LF2 / Alloy 20 / 3000# / 6000# / 9000# Unions / Tees / Reducers / 45 / 90 / Plugs / Caps / Bushings / Street 90 / Couplings / Inserts	
Outlets	Carbon / Stainless / Chrome / WOL / TOL / SOL / EOL / LOL	
CAPABILITIES		
Machining	Tapering / Tapping / Threading / Facing / Socket Welding / Thru Boring / Specials	
Manufacturing	Alloy Piping Products is a domestic manufacturer of butt-weld fittings in all grades of material, and a master distributor for many other related product lines, stocking both domestic and import material.	
For emergency items, we maintain a substantial inventory of raw materials to provide quick-response manufacturing capability.		

Nominal Wall Thickness, Outside & Inside Diameters

Pipe Size	Outside Diameter	Sch 5		Sch 10s		Sch 10		Sch 20		Sch 30		Sch 40s or STD		Sch 40		Sch 60	
		Wall	I.D.	Wall	I.D.	Wall	I.D.	Wall	I.D.	Wall	I.D.	Wall	I.D.	Wall	I.D.	Wall	I.D.
1/8	.405			.049	.307							.068	.269	.068	.269		
1/4	.540			.065	.410							.088	.364	.088	.364		
3/8	.675			.065	.545							.091	.493	.091	.493		
1/2	.840	.065	.710	.083	.674							.109	.622	.109	.622		
3/4	1.050	.065	.920	.083	.884							.113	.824	.113	.824		
1	1.315	.065	1.185	.109	1.097							.133	1.049	.133	1.049		
1 1/4	1.660	.065	1.530	.109	1.442							.140	1.380	.140	1.380		
1 1/2	1.900	.065	1.770	.109	1.682							.145	1.610	.145	1.610		
2	2.375	.065	2.245	.109	2.157							.154	2.067	.154	2.067		
2 1/2	2.875	.083	2.709	.120	2.635							.203	2.469	.203	2.469		
3	3.500	.083	3.334	.120	3.260							.216	3.068	.216	3.068		
3 1/2	4.000	.083	3.834	.120	3.760							.226	3.548	.226	3.548		
4	4.500	.083	4.334	.120	4.260							.237	4.026	.237	4.026		
5	5.563	.109	5.345	.134	5.295							.258	5.047	.258	5.047		
6	6.625	.109	6.407	.134	6.357							.280	6.065	.280	6.065		
8	8.625	.109	8.407	.148	8.329			.250	8.125	.277	8.071	.322	7.981	.322	7.981	.406	7.813
10	10.750	.134	10.482	.165	10.420			.250	10.250	.307	10.136	.365	10.020	.365	10.020	.500	9.750
12	12.750	.156	12.438	.180	12.390			.250	12.250	.330	12.090	.375	12.000	.406	11.938	.562	11.626
14	14.000	.156	13.688	.188	13.624	.250	13.500	.312	13.376	.375	13.250	.375	13.250	.438	13.124	.594	12.812
16	16.000	.165	15.670	.188	15.624	.250	15.500	.312	15.376	.375	15.250	.375	15.250	.500	15.000	.656	14.688
18	18.000	.165	17.670	.188	17.624	.250	17.500	.312	17.376	.438	17.124	.375	17.250	.562	16.876	.750	16.500
20	20.000	.188	19.624	.218	19.564	.250	19.500	.375	19.250	.500	19.000	.375	19.250	.594	18.812	.812	18.376
22	22.000	.188	21.624	.218	21.564	.250	21.500	.375	21.250	.500	21.000	.375	21.250			.875	20.250
24	24.000	.218	23.564	.250	23.500	.250	23.500	.375	23.250	.562	22.876	.375	23.250	.688	22.624	.969	22.062
26	26.000					.312	25.376	.500	25.000			.375	25.250				
28	28.000					.312	27.376	.500	27.000	.625	26.750	.375	27.250				
30	30.000	.250	29.500	.312	29.376	.312	29.376	.500	29.000	.625	28.750	.375	29.250				
32	32.000					.312	31.376	.500	31.000	.625	30.750	.375	31.250	.688	30.624		
34	34.000					.312	33.376	.500	33.000	.625	32.750	.375	33.250	.688	32.624		
36	36.000					.312	35.376	.500	35.000	.625	34.750	.375	35.250	.750	34.500		
38	38.000											.375	37.250				
40	40.000											.375	39.250				
42	42.000											.375	41.250				
44	44.000											.375	43.250				
46	46.000											.375	45.250				
48	48.000											.375	47.250				

Unless otherwise stated, all dimensions in this brochure are in inches.

Pipe Size	Outside Diameter	Sch 80s or XH		Sch 80		Sch 100		Sch 120		Sch 140		Sch 160		XXH	
		Wall	I.D.	Wall	I.D.	Wall	I.D.	Wall	I.D.	Wall	I.D.	Wall	I.D.	Wall	I.D.
1/8	.405	.095	.215	.095	.215										
1/4	.540	.119	.302	.119	.302										
3/8	.675	.126	.423	.126	.423										
1/2	.840	.147	.546	.147	.546							.187	.466	.294	.252
3/4	1.050	.154	.742	.154	.742							.219	.612	.308	.434
1	1.315	.179	.957	.179	.957							.250	.815	.358	.599
1 1/4	1.660	.191	1.278	.191	1.278							.250	1.160	.382	.896
1 1/2	1.900	.200	1.500	.200	1.500							.281	1.338	.400	1.100
2	2.375	.218	1.939	.218	1.939							.344	1.687	.436	1.503
2 1/2	2.875	.276	2.323	.276	2.323							.375	2.125	.552	1.771
3	3.500	.300	2.900	.300	2.900							.438	2.624	.600	2.300
3 1/2	4.000	.318	3.364	.318	3.364									.636	2.728
4	4.500	.337	3.826	.337	3.826			.438	3.624			.531	3.438	.674	3.152
5	5.563	.375	4.813	.375	4.813			.500	4.563			.625	4.313	.750	4.063
6	6.625	.432	5.761	.432	5.761			.562	5.501			.719	5.187	.864	4.897
8	8.625	.500	7.625	.500	7.625	.594	7.437	.719	7.187	.812	7.001	.906	6.813	.875	6.875
10	10.750	.500	9.750	.594	9.562	.719	9.312	.844	9.062	1.000	8.750	1.125	8.500	1.000	8.750
12	12.750	.500	11.750	.688	11.374	.844	11.062	1.000	10.750	1.125	10.500	1.312	10.126	1.000	10.750
14	14.000	.500	13.000	.750	12.500	.938	12.124	1.094	11.812	1.250	11.500	1.406	11.188		
16	16.000	.500	15.000	.844	14.312	1.031	13.938	1.219	13.562	1.438	13.124	1.594	12.812		
18	18.000	.500	17.000	.938	16.124	1.156	15.688	1.375	15.250	1.562	14.876	1.781	14.438		
20	20.000	.500	19.000	1.031	17.938	1.281	17.438	1.500	17.000	1.750	16.500	1.969	16.062		
22	22.000	.500	21.000	1.125	19.750	1.375	19.250	1.625	18.750	1.875	18.250	2.125	17.750		
24	24.000	.500	23.000	1.219	21.562	1.531	20.938	1.812	20.376	2.062	19.876	2.344	19.312		
26	26.000	.500	25.000												
28	28.000	.500	27.000												
30	30.000	.500	29.000												
32	32.000	.500	31.000												
34	34.000	.500	33.000												
36	36.000	.500	35.000												
38	38.000	.500	37.000												
40	40.000	.500	39.000												
42	42.000	.500	41.000												
44	44.000	.500	43.000												
46	46.000	.500	45.000												
48	48.000	.500	47.000												

Toll Free: 800 551 8392

Metric Outside Diameter & Nominal Wall Thickness

Pipe Size		Outside Diameter		Sch 5		Sch 10s		Sch 10		Sch 20		Sch 30		Sch 40s or STD		Sch 40		Sch 60	
IPS	MM	O.D.	MM	Wall	MM	Wall	MM	Wall	MM	Wall	MM	Wall	MM	Wall	MM	Wall	MM	Wall	MM
1/8		.405	10.29			.049	1.24							.068	1.73	.068	1.73		
1/4		.540	13.72			.065	1.65							.088	2.24	.088	2.24		
3/8	10	.675	17.15			.065	1.65							.091	2.31	.091	2.31		
1/2	15	.840	21.34	.065	1.65	.083	2.11							.109	2.77	.109	2.77		
3/4	20	1.050	26.67	.065	1.65	.083	2.11							.113	2.87	.113	2.87		
1	25	1.315	33.40	.065	1.65	.109	2.77							.133	3.38	.133	3.38		
1 1/4	32	1.660	42.16	.065	1.65	.109	2.77							.140	3.56	.140	3.56		
1 1/2	40	1.900	48.26	.065	1.65	.109	2.77							.145	3.68	.145	3.68		
2	50	2.375	60.33	.065	1.65	.109	2.77							.154	3.91	.154	3.91		
2 1/2	65	2.875	73.03	.083	2.11	.120	3.05							.203	5.16	.203	5.16		
3	80	3.500	88.90	.083	2.11	.120	3.05							.216	5.49	.216	5.49		
3 1/2	90	4.000	101.60	.083	2.11	.120	3.05							.226	5.74	.226	5.74		
4	100	4.500	114.30	.083	2.11	.120	3.05							.237	6.02	.237	6.02		
5	125	5.563	141.30	.109	2.77	.134	3.40							.258	6.55	.258	6.55		
6	150	6.625	168.28	.109	2.77	.134	3.40							.280	7.11	.280	7.11		
8	200	8.625	219.08	.109	2.77	.148	3.76			.250	6.35	.277	7.04	.322	8.18	.322	8.18	.406	10.31
10	250	10.750	273.05	.134	3.40	.165	4.19			.250	6.35	.307	7.80	.365	9.27	.365	9.27	.500	12.70
12	300	12.750	323.85	.156	3.96	.180	4.57			.250	6.35	.330	8.38	.375	9.53	.406	10.31	.562	14.27
14	350	14.000	355.60	.156	3.96	.188	4.78	.250	6.35	.312	7.92	.375	9.53	.375	9.53	.438	11.13	.594	15.09
16	400	16.000	406.40	.165	4.19	.188	4.78	.250	6.35	.312	7.92	.375	9.53	.375	9.53	.500	12.70	.656	16.66
18	450	18.000	457.20	.165	4.19	.188	4.78	.250	6.35	.312	7.92	.438	11.13	.375	9.53	.562	14.27	.750	19.05
20	500	20.000	508.00	.188	4.78	.218	5.54	.250	6.35	.375	9.53	.500	12.70	.375	9.53	.594	15.09	.812	20.62
22	550	22.000	558.80	.188	4.78	.218	5.54	.250	6.35	.375	9.53	.500	12.70	.375	9.53			.875	22.23
24	600	24.000	609.60	.218	5.54	.250	6.35	.250	6.35	.375	9.53	.562	14.27	.375	9.53	.688	17.48	.969	24.61
26	650	26.000	660.40					.312	7.92	.500	12.70			.375	9.53				
28	700	28.000	711.20					.312	7.92	.500	12.70	.625	15.88	.375	9.53				
30	750	30.000	762.00	.250	6.35	.312	7.92	.312	7.92	.500	12.70	.625	15.88	.375	9.53				
32	800	32.000	812.80					.312	7.92	.500	12.70	.625	15.88	.375	9.53	.688	17.48		
34	850	34.000	863.60					.312	7.92	.500	12.70	.625	15.88	.375	9.53	.688	17.48		
36	900	36.000	914.40					.312	7.92	.500	12.70	.625	15.88	.375	9.53	.750	19.05		
38	950	38.000	965.20											.375	9.53				
40	1000	40.000	1016.00											.375	9.53				
42	1050	42.000	1066.80											.375	9.53				
44	1100	44.000	1117.60											.375	9.53				
46	1150	46.000	1168.40											.375	9.53				
48	1200	48.000	1219.20											.375	9.53				

Pipe Size		Outside Diameter		Sch 80s or XH		Sch 80		Sch 100		Sch 120		Sch 140		Sch 160		XXH	
IPS	MM	O.D.	MM	Wall	MM	Wall	MM	Wall	MM	Wall	MM	Wall	MM	Wall	MM	Wall	MM
1/8		.405	10.29	.095	2.41	.095	2.41										
1/4		.540	13.72	.119	3.02	.119	3.02										
3/8	10	.675	17.15	.126	3.20	.126	3.20										
1/2	15	.840	21.34	.147	3.73	.147	3.73						.187	4.75	.294	7.47	
3/4	20	1.050	26.67	.154	3.91	.154	3.91						.219	5.56	.308	7.82	
1	25	1.315	33.40	.179	4.55	.179	4.55						.250	6.35	.358	9.09	
1 1/4	32	1.660	42.16	.191	4.85	.191	4.85						.250	6.35	.382	9.70	
1 1/2	40	1.900	48.26	.200	5.08	.200	5.08						.281	7.14	.400	10.16	
2	50	2.375	60.33	.218	5.54	.218	5.54						.344	8.74	.436	11.07	
2 1/2	65	2.875	73.03	.276	7.01	.276	7.01						.375	9.53	.552	14.02	
3	80	3.500	88.90	.300	7.62	.300	7.62						.438	11.13	.600	15.24	
3 1/2	90	4.000	101.60	.318	8.08	.318	8.08								.636	16.15	
4	100	4.500	114.30	.337	8.56	.337	8.56			.438	11.13			.531	13.49	.674	17.12
5	125	5.563	141.30	.375	9.53	.375	9.53			.500	12.70			.625	15.88	.750	19.05
6	150	6.625	168.28	.432	10.97	.432	10.97			.562	14.27			.719	18.26	.864	21.95
8	200	8.625	219.08	.500	12.70	.500	12.70	.594	15.09	.719	18.26	.812	20.62	.906	23.01	.875	22.23
10	250	10.750	273.05	.500	12.70	.594	15.09	.719	18.26	.844	21.44	1.000	25.40	1.125	28.58	1.000	25.40
12	300	12.750	323.85	.500	12.70	.688	17.48	.844	21.44	1.000	25.40	1.125	28.58	1.312	33.32	1.000	25.40
14	350	14.000	355.60	.500	12.70	.750	19.05	.938	23.83	1.094	27.79	1.250	31.75	1.406	35.71		
16	400	16.000	406.40	.500	12.70	.844	21.44	1.031	26.19	1.219	30.96	1.438	36.53	1.594	40.49		
18	450	18.000	457.20	.500	12.70	.938	23.83	1.156	29.36	1.375	34.93	1.562	39.67	1.781	45.24		
20	500	20.000	508.00	.500	12.70	1.031	26.19	1.281	32.54	1.500	38.10	1.750	44.45	1.969	50.01		
22	550	22.000	558.80	.500	12.70	1.125	28.58	1.375	34.93	1.625	41.28	1.875	47.63	2.125	53.98		
24	600	24.000	609.60	.500	12.70	1.219	30.96	1.531	38.89	1.812	46.02	2.062	52.37	2.344	59.54		
26	650	26.000	660.40	.500	12.70												
28	700	28.000	711.20	.500	12.70												
30	750	30.000	762.00	.500	12.70												
32	800	32.000	812.80	.500	12.70												
34	850	34.000	863.60	.500	12.70												
36	900	36.000	914.40	.500	12.70												
38	950	38.000	965.20	.500	12.70												
40	1000	40.000	1016.00	.500	12.70												
42	1050	42.000	1066.80	.500	12.70												
44	1100	44.000	1117.60	.500	12.70												
46	1150	46.000	1168.40	.500	12.70												
48	1200	48.000	1219.20	.500	12.70												

Toll Free: 800 551 8392

Long Radius/Short Radius Elbows

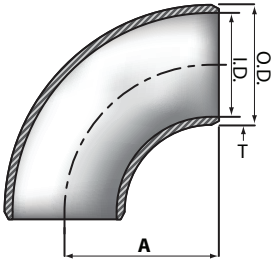

90° elbow long radius

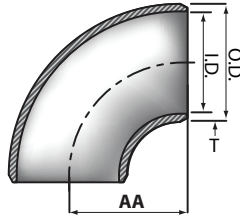

90° elbow short radius

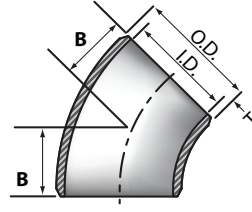

45° elbow long radius

Pipe Size	Outside Diameter	90° Elbow		45° Elbow
		Long Radius	Short Radius	Long Radius
IPS	O.D.	A	AA	B
1/2	.840	1 1/2		5/8
3/4	1.050	1 1/2		3/4
1	1.315	1 1/2	1	7/8
1 1/4	1.660	1 7/8	1 1/4	1
1 1/2	1.900	2 1/4	1 1/2	1 1/8
2	2.375	3	2	1 3/8
2 1/2	2.875	3 3/4	2 1/2	1 3/4
3	3.500	4 1/2	3	2
3 1/2	4.000	5 1/4	3 1/2	2 1/4
4	4.500	6	4	2 1/2
5	5.563	7 1/2	5	3 1/8
6	6.625	9	6	3 3/4
8	8.625	12	8	5
10	10.750	15	10	6 1/4
12	12.750	18	12	7 1/2
14	14.000	21	14	8 3/4
16	16.000	24	16	10
18	18.000	27	18	11 1/4
20	20.000	30	20	12 1/2
24	24.000	36	24	15
30	30.000	45	30	18 1/2
36	36.000	54	36	22 1/4

Domestic & Import

Pipe - Fittings - Flanges - Forged Fittings
Carbon - Chrome - Stainless

WPB - WPC - Low Temp - High Yield

WP11 - WP22 - WP5 - WP9 - WP91

304/L - 304H - 316/L - 316H - 317/L - 321/H - 347/H - Alloy 20 - Duplex

Toll Free: 800 551 8392

Concentric and Eccentric Reducers

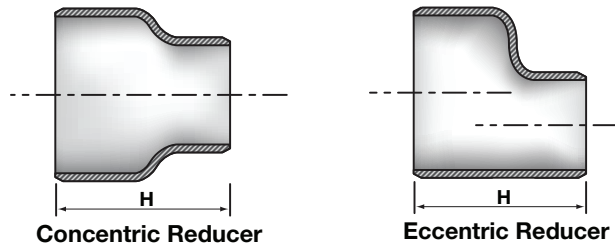

Pipe Size		H	Pipe Size	H	Pipe Size	H		
3/4	x 1/2	1 1/2	4	x 1 1/2	4	14	x 8	13
1	x 1/2	2		x 2	4		x 10	13
	x 3/4	2		x 2 1/2	4		x 12	13
1 1/4	x 1/2	2	5	x 3	4	16	x 5	14
	x 3/4	2		x 3 1/2	4		x 6	14
	x 1	2		x 2	5		x 8	14
1 1/2	x 1/2	2 1/2	6	x 2 1/2	5	18	x 10	14
	x 3/4	2 1/2		x 3	5		x 10	15
	x 1	2 1/2		x 3 1/2	5		x 12	15
	x 1 1/4	2 1/2		x 4	5		x 14	15
2	x 3/4	3	8	x 2 1/2	5 1/2	20	x 16	15
	x 1	3		x 3	5 1/2		x 10	20
	x 1 1/4	3		x 3 1/2	5 1/2		x 12	20
	x 1 1/2	3		x 4	5 1/2		x 14	20
2 1/2	x 1	3 1/2	10	x 5	5 1/2	24	x 16	20
	x 1 1/4	3 1/2		x 3 1/2	6		x 18	20
	x 1 1/2	3 1/2		x 4	6		x 12	20
	x 2	3 1/2		x 5	6		x 14	20
3	x 1 1/4	3 1/2	12	x 6	6	30	x 16	20
	x 1 1/2	3 1/2		x 4	7		x 18	20
	x 2	3 1/2		x 5	7		x 20	20
	x 2 1/2	3 1/2		x 6	7		x 18	24
3 1/2	x 1 1/4	4	12	x 8	7	36	x 20	24
	x 1 1/2	4		x 5	8		x 24	24
	x 2	4		x 6	8		x 24	24
	x 2 1/2	4		x 8	8		x 30	24
	x 3	4		x 10	8			

Tees and Crosses

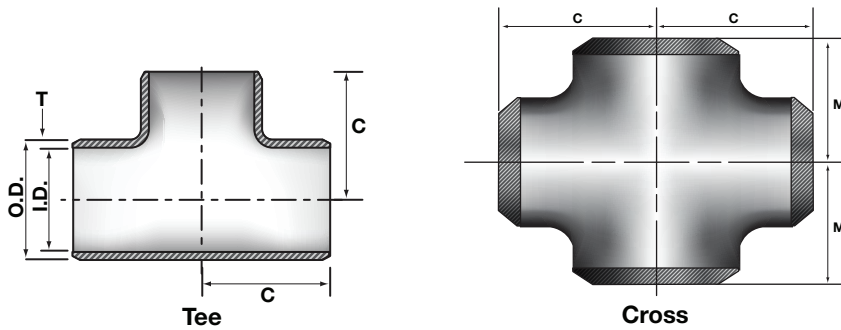

Pipe Size	Outside Diameter	C/M
1/2	.840	1
3/4	1.050	1 1/8
1	1.315	1 1/2
1 1/4	1.660	1 7/8
1 1/2	1.900	2 1/4
2	2.375	2 1/2
2 1/2	2.875	3
3	3.500	3 3/8
3 1/2	4.000	3 3/4
4	4.500	4 1/8
5	5.563	4 7/8
6	6.625	5 5/8
8	8.625	7
10	10.750	8 1/2
12	12.750	10
14	14.000	11
16	16.000	12
18	18.000	13 1/2
20	20.000	15
24	24.000	17

Domestic & Import
Pipe - Fittings - Flanges - Forged Fittings
Carbon - Chrome - Stainless

WPB - WPC - Low Temp - High Yield
WP11 - WP22 - WP5 - WP9 - WP91
304/L - 304H - 316/L - 316H - 317/L - 321/H - 347/H - Alloy 20 - Duplex

Toll Free: 800 551 8392

Reducing Tees

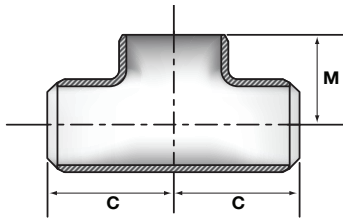

Pipe Size		Reducing Tee		Pipe Size		Reducing Tee	
		C	M			C	M
3/4	x 1/2	1 1/8	1 1/8	6	x 2 1/2	5 5/8	4 3/4
1	x 1/2	1 1/2	1 1/2		x 3	5 5/8	4 7/8
	x 3/4	1 1/2	1 1/2		x 3 1/2	5 5/8	5
1 1/4	x 1/2	1 7/8	1 7/8		x 4	5 5/8	5 1/8
	x 3/4	1 7/8	1 7/8	x 5	5 5/8	5 3/8	
1 1/2	x 1	1 7/8	1 7/8	8	x 3 1/2	7	6
	x 1/2	2 1/4	2 1/4		x 4	7	6 1/6
	x 3/4	2 1/4	2 1/4		x 5	7	6 3/8
	x 1	2 1/4	2 1/4		x 6	7	6 5/8
2	x 3/4	2 1/2	1 3/4	10	x 4	8 1/2	7 1/4
	x 1	2 1/2	2		x 5	8 1/2	7 1/2
	x 1 1/4	2 1/2	2 1/4		x 6	8 1/2	7 5/8
	x 1 1/2	2 1/2	2 3/8		x 8	8 1/2	8
2 1/2	x 1	3	2 1/4	12	x 5	10	8 1/2
	x 1 1/4	3	2 1/2		x 6	10	8 5/8
	x 1 1/2	3	2 5/8		x 8	10	9
	x 2	3	2 3/4		x 10	10	9 1/2
3	x 1 1/4	3 3/8	2 3/4	14	x 8	11	9 3/4
	x 1 1/2	3 3/8	2 7/8		x 10	11	10 1/8
	x 2	3 3/8	3		x 12	11	10 5/8
	x 2 1/2	3 3/8	3 1/4		x 6	12	11 1/8
3 1/2	x 1 1/2	3 3/4	3 1/8	16	x 8	12	11 5/8
	x 2	3 3/4	3 1/4		x 10	12	12
	x 2 1/2	3 3/4	3 1/2		x 12	12	12 1/8
	x 3	3 3/4	3 5/8		x 14	12	12 5/8
4	x 1 1/2	4 1/8	3 3/8	18	x 10	13 1/2	12 1/8
	x 2	4 1/8	3 1/2		x 12	13 1/2	12 5/8
	x 2 1/2	4 1/8	3 3/4		x 14	13 1/2	13
	x 3	4 1/8	3 5/8		x 16	13 1/2	13
	x 3 1/2	4 1/8	4		x 10	15	13 1/8
5	x 2	4 7/8	4 1/8	20	x 12	15	13 5/8
	x 2 1/2	4 7/8	4 1/4		x 14	15	14
	x 3	4 7/8	4 3/8		x 16	15	14
	x 3 1/2	4 7/8	4 1/2		x 18	15	14 1/2
	x 4	4 7/8	4 5/8		x 12	17	15 5/8
24	x 14	17	16	24	x 14	17	16
	x 16	17	16		x 16	17	16
	x 18	17	16 1/2		x 18	17	16 1/2
	x 20	17	17		x 20	17	17

Caps

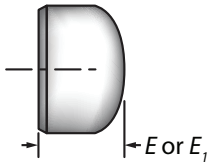

Pipe Size	Outside Diameter	Cap	Cap
		E	E1
1/2	.840	1	
3/4	1.050	1	
1	1.315	1 1/2	
1 1/4	1.660	1 1/2	
1 1/2	1.900	1 1/2	
2	2.375	1 1/2	1 3/4
2 1/2	2.875	1 1/2	2
3	3.500	2	2 1/2
3 1/2	4.000	2 1/2	3
4	4.500	2 1/2	3
5	5.563	3	3 1/2
6	6.625	3 1/2	4
8	8.625	4	5
10	10.750	5	6
12	12.750	6	7
14	14.000	6 1/2	7 1/2
16	16.000	7	8
18	18.000	8	9
20	20.000	9	10
24	24.000	10 1/2	12

Per ANSI B16.9 NOTES:

(1) Length E applies for thickness not exceeding that given in column "Limiting Wall Thickness for Length, E."

(2) Length E1 applies for thickness greater than that given in column "Limiting Wall Thickness" for NPS 24 and smaller.

Domestic & Import
Pipe - Fittings - Flanges - Forged Fittings
Carbon - Chrome - Stainless

WPB - WPC - Low Temp - High Yield
WP11 - WP22 - WP5 - WP9 - WP91
304/L - 304H - 316/L - 316H - 317/L - 321/H - 347/H - Alloy 20 - Duplex

Toll Free: 800 551 8392

Stub Ends

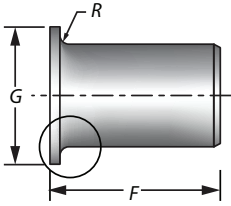

Pipe Size	Outside Diameter	Length		G	Radius	
		F (short)	F (long)		Type A	Type B
1/2	.840	2	3	1 3/8	1/8	1/32
3/4	1.050	2	3	1 11/16	1/8	1/32
1	1.315	2	4	2	1/8	1/32
1 1/4	1.660	2	4	2 1/2	3/16	1/32
1 1/2	1.900	2	4	2 7/8	1/4	1/32
2	2.375	2 1/2	6	3 5/8	5/16	1/32
2 1/2	2.875	2 1/2	6	4 1/8	5/16	1/32
3	3.500	2 1/2	6	5	3/8	1/32
3 1/2	4.000	3	6	5 1/2	3/8	1/32
4	4.500	3	6	6 3/16	7/16	1/32
5	5.563	3	8	7 5/16	7/16	1/16
6	6.625	3 1/2	8	8 1/2	1/2	1/16
8	8.625	4	8	10 5/8	1/2	1/16
10	10.750	5	10	12 3/4	1/2	1/16
12	12.750	6	10	15	1/2	1/16
14	14.000	6	12	16 1/4	1/2	1/16
16	16.000	6	12	18 1/2	1/2	1/16
18	18.000	6	12	21	1/2	1/16
20	20.000	6	12	23	1/2	1/16
24	24.000	6	12	27 1/4	1/2	1/16
26	26.000	6	12	29 1/2	1/2*	1/16*
28	28.000	6	12	31 1/2	1/2*	1/16*
30	30.000	6	12	33 3/4	1/2*	1/16*
32	32.000	6	12	35 3/4	1/2*	1/16*
34	34.000	6	12	37 3/4	1/2*	1/16*
36	36.000	6	12	40 1/4	1/2*	1/16*
38	38.000	6	12	42 1/4	1/2*	1/16*
40	40.000	6	12	44 1/4	1/2*	1/16*
42	42.000	6	12	46 1/2	1/2*	1/16*
44	44.000	6	12	48 7/8	1/2*	1/16*
46	46.000	6	12	50 7/8	1/2*	1/16*
48	48.000	6	12	52 7/8	1/2*	1/16*

*not covered by MSS or B16.9.

LR Return Bends

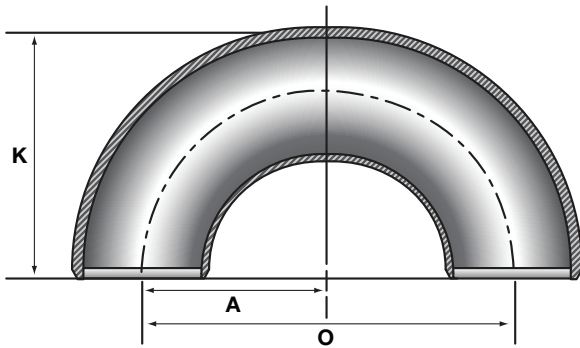

Pipe Size	Outside Diameter	Center to Center	Back To Face
IPS	O.D.	O	K
1/2	.840	3.00	1.88
3/4	1.050	3.00	2.00
1	1.315	3.00	2.19
1 1/4	1.660	3.75	2.75
1 1/2	1.900	4.50	3.25
2	2.375	6.00	4.19
2 1/2	2.875	7.50	5.19
3	3.500	9.00	6.25
3 1/2	4.000	10.50	7.25
4	4.500	12.00	8.25
5	5.563	15.00	10.31
6	6.625	18.00	12.31
8	8.625	24.00	16.31

Dimension A is equal to one-half of dimension O.

Domestic & Import
Pipe - Fittings - Flanges - Forged Fittings
Carbon - Chrome - Stainless

WPB - WPC - Low Temp - High Yield
WP11 - WP22 - WP5 - WP9 - WP91
304/L - 304H - 316/L - 316H - 317/L - 321/H - 347/H - Alloy 20 - Duplex

Toll Free: 800 551 8392

Schedule 10s Weights

Nominal Pipe Size	90° Elbow		45° Elbow	Tee	Lap Joint Stub Ends		Cap	180° Return Bends	Crosses
	Long Radius	Short Radius	Long Radius		MSS Length	ASA Length			
1/2	.13	--	.06	.20	.17	.20	.03	.26	
3/4	.16	--	.08	.28	.21	.25	.03	.41	
1	.38	--	.25	.60	.33	.52	.10	.75	.72
1 1/4	.50	--	.33	1.10	.45	.70	.13	1.26	1.26
1 1/2	.75	--	.47	1.50	.57	.87	.23	1.75	1.72
2	1.10	--	.60	1.80	.91	1.66	.30	3.13	2.15
2 1/2	1.80	--	1.00	3.00	1.05	2.03	.40	5.88	3.56
3	2.50	--	1.30	3.90	1.61	3.04	.72	9.81	4.48
3 1/2	3.40	--	1.70	4.90	2.07	3.48	.83	10.5	6.76
4	4.30	--	2.20	5.70	2.52	4.17	1.16	13.6	8.77
5	7.40	5.19	3.80	12.0	3.44	7.13	1.61	16.0	15.46
6	11.0	7.45	5.50	17.0	4.79	8.85	1.93	24.0	20.47
8	21.0	31.0	11.0	25.0	7.62	12.9	2.78	47.0	39.67
10	36.0	24.9	18.0	47.0	12.1	21.0	4.66	--	67.85
12	57.0	38.1	29.0	119.0	17.9	26.9	7.05	--	--
14	78.0	51.7	39.4	59.6	22.3	37.8	9.20	--	--
16	102.	67.7	51.0	75.9	27.5	43.9	11.5	--	--
18	129.	85.7	64.5	94.7	35.2	46.9	14.5	--	--
20	185.	122.	92.5	130.	49.8	67.1	20.5	--	--
24	306.	203.	153.	200.	77.4	118	32.9	--	--
30	596.	388.	298.	--	--	--	--	--	--

Nominal Pipe Size	Reducing Tee	Reducers	Nominal Pipe Size	Reducing Tee	Reducers	Nominal Pipe Size	Reducing Tee	Reducers			
3/4	x 1/2	.28	.16	4	x 1 1/2	5.38	2.09	12	x 5	49.8	18.7
1	x 1/2	.56	.37		x 2	5.43	2.16		x 6	51.7	19.2
	x 3/4	.60	.38		x 2 1/2	5.45	2.22		x 8	53.0	20.4
1 1/4	x 1/2	1.06	.39		x 3	5.60	2.28		x 10	54.0	20.9
	x 3/4	1.10	.42	x 3 1/2	5.70	2.41	14	x 8	52.5	29.8	
	x 1	1.15	.44	x 2	10.8	3.35		x 10	53.5	30.5	
1 1/2	x 1/2	1.33	.49	5	x 2 1/2	11.1	3.64	16	x 12	54.3	31.2
	x 3/4	1.41	.53		x 3	11.4	3.90		x 8	67.1	33.6
	x 1	1.45	.56		x 3 1/2	11.7	4.30		x 10	39.3	34.1
	x 1 1/4	1.50	.59		x 4	12.0	4.29		x 12	71.2	34.6
2	x 3/4	1.37	.71	6	x 2 1/2	15.7	4.79	18	x 14	72.4	35.7
	x 1	1.67	.78		x 3	16.0	5.04		x 10	83.5	45.6
	x 1 1/4	1.72	.82		x 3 1/2	16.2	5.28		x 12	86.5	46.6
	x 1 1/2	1.80	.85		x 4	16.5	5.52		x 14	88.7	47.5
2 1/2	x 1	2.49	1.04	8	x 5	17.0	5.76	20	x 16	90.2	48.5
	x 1 1/4	1.62	1.09		x 3 1/2	23.4	6.88		x 10	126	83.2
	x 1 1/2	2.74	1.12		x 4	23.9	7.10		x 12	126	84.6
	x 2	3.00	1.18		x 5	24.5	7.51		x 14	126	85.5
3	x 1 1/4	3.61	1.33	10	x 6	25.0	7.80	24	x 16	127	86.3
	x 1 1/2	3.65	1.39		x 4	30.1	10.5		x 18	128	87.6
	x 2	3.75	1.45		x 5	32.3	12.6		x 12	191	107
	x 2 1/2	3.90	1.53		x 6	36.3	13.3		x 14	192	121
3 1/2	x 1 1/2	4.20	1.73	12	x 8	37.0	14.0	24	x 16	193	125
	x 2	4.49	1.83		x 5	49.8	18.7		x 18	194	128
	x 2 1/2	4.73	1.96		x 6	51.7	19.2		x 20	195	132
	x 3	4.90	2.12		x 8	53.0	20.4				
					x 10	54.0	20.9				

Schedule 40s Weights

Nominal Pipe Size	90° Elbow		45° Elbow	Tee	Lap Joint Stub Ends		Cap	180° Return Bends	Crosses
	Long Radius	Short Radius	Long Radius		MSS Length	ASA Length			
1/2	.18	--	.09	.35	.25	.30	.12	.34	
3/4	.19	--	.09	.45	.34	.40	.16	.50	
1	.40	0.25	.25	.75	.43	.68	.20	.76	.65
1 1/4	.60	.40	.38	1.30	.60	.93	.30	1.66	1.32
1 1/2	.90	.56	.40	2.00	.75	1.14	.40	2.33	1.91
2	1.60	1.00	.81	3.50	1.22	2.22	.60	4.38	2.86
2 1/2	3.25	2.13	1.75	6.00	1.82	3.51	.90	7.75	4.90
3	5.00	3.00	2.63	7.00	2.49	4.70	1.50	12.83	7.37
3 1/2	6.75	4.50	3.50	9.00	3.36	5.65	2.00	15.60	9.09
4	9.00	6.25	4.50	12.0	4.12	6.81	2.50	24.50	11.74
5	15.5	9.60	7.50	21.0	5.69	11.8	4.50	31.00	20.95
6	24.5	18.0	12.0	34.0	8.28	15.3	6.50	48.00	24.49
8	50.5	34.0	23.0	55.0	13.6	23.1	12.0	95.00	46.56
10	88.0	58.0	42.0	104.	23.0	39.9	20.0	--	78.78
12	125.	80.0	62.0	144.	32.7	49.2	30.0	--	--
14	160.	105.	80.0	165.	37.6	63.8	36.0	--	--
16	206.	132.	100.	195.	46.3	73.9	40.0	--	--
18	260.	167.	126.	249.	64.0	85.2	54.0	--	--
20	320.	210.	160.	342.	74.2	100.	75.0	--	--
24	460.	298.	238.	528.	95.0	145.	96.0	--	--
30	734.	464.	367.	--	--	--	--	--	--
36	1062.	671.	531.	--	--	--	--	--	--

Nominal Pipe Size	Reducing Tee	Reducers	Nominal Pipe Size	Reducing Tee	Reducers	Nominal Pipe Size	Reducing Tee	Reducers	
3/4	x 1/2	.50	4	x 1 1/2	11.1	14	x 8	155	
1	x 1/2	.88		x 2	11.2		3.00	x 10	158
	x 3/4	.93		x 2 1/2	11.2		3.25	x 12	160
1 1/4	x 1/2	1.50	5	x 3	11.6	16	x 8	180	
	x 3/4	1.50		x 3 1/2	11.8		3.50	x 10	186
1 1/2	x 1	1.50	6	x 2	19.0	18	x 12	191	
	x 1/2	2.00		x 2 1/2	19.5		5.25	x 14	194
	x 3/4	2.13		x 3	20.0		5.50	x 10	222
	x 1	2.18		x 3 1/2	20.5		5.75	x 12	230
2	x 1 1/4	2.25	8	x 4	21.0	20	x 14	236	
	x 3/4	3.25		x 2 1/2	32.0		7.25	x 16	241
	x 1	3.50		x 3	32.5		8.00	x 10	332
2 1/2	x 1 1/4	3.60	10	x 3 1/2	33.0	24	x 12	334	
	x 1 1/2	3.75		x 4	33.5		8.25	x 14	336
	x 1	5.00		x 5	34.5		8.50	x 16	338
	x 1 1/4	5.25		x 3 1/2	50.7		11.0	x 18	340
3	x 1 1/2	5.50	12	x 4	51.7	24	x 12	510	
	x 2	6.00		x 5	53.0		12.0	x 14	513
	x 1 1/4	6.25		x 6	54.0		13.2	x 16	516
	x 1 1/2	6.25		x 4	80.0		20.0	x 18	519
3 1/2	x 2	6.50	12	x 5	81.0	24	x 20	522	
	x 2 1/2	6.75		x 6	83.0		21.5		
	x 1 1/2	8.00		x 8	84.5		22.0		
	x 2	8.30		x 5	110		30.0		
3 1/2	x 2 1/2	8.50	12	x 6	114	31.0			
	x 3	8.80		x 8	117	32.0			
				x 10	119	34.0			

Schedule 80s Weights

Nominal Pipe Size	90° Elbow		45° Elbow	Tee	Lap Joint Stub Ends		Cap	180° Return Bends	Crosses
	Long Radius	Short Radius	Long Radius		ASA Length	MSS Length			
1/2	.25	--	.19	.45	.46	.38	.15	.43	
3/4	.25	--	.19	.60	.51	.51	.20	.69	
1	.50	0.41	.31	.88	1.38	.87	.30	1.38	.86
1 1/4	.90	0.63	.50	1.60	1.92	1.24	.40	2.50	1.51
1 1/2	1.15	0.75	.69	2.25	2.30	1.51	.50	3.00	2.27
2	2.20	1.5	1.19	4.00	5.64	3.10	.75	6.21	3.53
2 1/2	4.00	2.8	2.13	7.00	8.95	4.64	1.00	9.71	6.97
3	6.50	4.25	3.50	8.50	12.0	6.36	1.75	17.19	9.9
3 1/2	8.35	6.00	4.50	12.0	13.0	7.71	2.50	22.00	12.12
4	13.5	8.50	6.10	15.7	15.5	9.37	3.00	34.30	17.17
5	22.0	14.0	10.7	26.0	34.7	16.7	5.50	43.00	25.25
6	35.0	23.0	17.5	40.0	42.5	23.0	9.00	72.00	30.3
8	71.0	47.5	35.0	75.0	59.3	34.9	16.0	146.00	62.62
10	107	70.0	53.0	105	93.0	53.6	25.0	--	111
12	160	104	84.0	160	97.4	64.7	36.0	--	--
14	205	140	100	240	57.7	34.0	45.0	--	--
16	276	174	135	280	155	97.4	54.0	--	--
18	340	219	167	332	149	112	72.0	--	--
20	420	275	206	480	170	126	86.0	--	--
24	600	392	300	610	232	152	130	--	--
30	975	618	488	--	--	--	--	--	--
36	1412	904	706	--	--	--	--	--	--

Nominal Pipe Size	Reducing Tee	Reducers	Nominal Pipe Size	Reducing Tee	Reducers	Nominal Pipe Size	Reducing Tee	Reducers		
3/4	x 1/2	.50	4	x 1 1/2	15.2	14	x 8	78.5		
1	x 1/2	1.00		x 2	15.5		4.25	x 10	223.	
	x 3/4	1.00		.45	x 2 1/2		15.5	4.38	x 12	237.
1 1/4	x 1/2	1.75	5	x 3	15.6	16	x 8	260.		
	x 3/4	1.75		.50	x 3 1/2		15.6	4.75	x 10	266.
	x 1	1.75		.50	x 2		23.5	6.50	x 12	270.
1 1/2	x 1/2	2.50	6	x 2 1/2	24.0	18	x 14	275.		
	x 3/4	2.50		.70	x 3		24.5	7.50	x 10	296
	x 1	2.50		.75	x 3 1/2		25.0	7.75	x 12	307
	x 1 1/4	2.50		.78	x 4		25.5	8.25	x 14	315
2	x 3/4	4.00	8	x 2 1/2	36.0	20	x 16	321		
	x 1	4.10		1.10	x 3		37.0	10.5	x 10	466
	x 1 1/4	4.13		1.15	x 3 1/2		38.2	11.0	x 12	469
	x 1 1/2	4.25		1.20	x 4		39.2	11.5	x 14	472
2 1/2	x 1	7.00	10	x 5	40.0	24	x 16	475		
	x 1 1/4	7.06		1.80	x 3 1/2		70.5	16.5	x 18	477
	x 1 1/2	7.13		1.85	x 4		71.7	17.0	x 12	592
	x 2	7.19		2.00	x 5		73.0	18.0	x 14	595
3	x 1 1/4	7.60	2.40	x 6	74.0	18.7	x 16	589		
	x 1 1/2	7.68	2.50	x 4	104	25.5	x 18	601		
	x 2	8.00	2.60	x 5	106	28.0	x 20	604		
	x 2 1/2	8.25	2.75	x 6	108	29.5				
3 1/2	x 1 1/2	11.5	3.25	x 8	109	29.5				
	x 2	11.8	3.50	x 5	160	39.0				
	x 2 1/2	12.2	3.50	x 6	165	40.0				
	x 3	12.6	4.00	x 8	175	42.0				
				x 10	184	43.5				

Toll Free: 800 551 8392

Schedule 160 Weights

	Nominal Pipe Size	90° Elbow		45° Elbow	Tee	Lap Joint Stub Ends		Cap	180° Return Bends
		Long Radius	Short Radius	Long Radius		ASA Length	MSS Length		
160	1/2	.46		.24	.60	.83	.68	.22	
	3/4	.5		.24	.90	.94	.94	.28	
	1	.96	.76	.62	1.70	2.80	1.76	.58	1.19
	1 1/4	1.76	1.26	1	3.00	3.90	2.52	.78	1.96
	1 1/2	2.26	1.76	1.26	4.50	4.54	2.98	1.08	3.17
	2	4	3.1	2.26	7.00	11.10	6.10	1.50	3.91
	2 1/2	8	5.76	4.38	13.80	17.0	8.80	2.24	9.4
	3	13.12	8.4	6.62	19.60	18.50	9.80	3.74	11.33
	3 1/2	17.6	10.7	8.8	24.00	26.13	15.50	5.00	--
	4	27.26	18.12	13.64	34.00	31.9	19.30	7.08	26.95
	5	42.26	32.2	21.12	50.00	67.9	32.66	11.26	41.91
	6	72	52	36	60.00	86.64	45.26	20.00	50.29
	8	127	109	63.87	108.00	101.46	59.71	22.76	113
	10	257	224	128	--	--	--	62	249
	12	459	328	230	--	--	--	96	--
	14	--	--	--	--	--	--	--	--
	16	--	--	--	--	--	--	--	--
18	--	--	--	--	--	--	--	--	
20	--	--	--	--	--	--	--	--	
24	--	--	--	--	--	--	--	--	

Nominal Pipe Size	Reducing Tee	Reducers	Nominal Pipe Size	Reducing Tee	Reducers	Reducing Tee	Reducers	Reducing Tee	Reducers		
3/4	x 1/2	.57	.55	4	x 1 1/2	22.56	6.56	14	x 8	--	--
1	x 1/2	1.04	.57		x 2	22.83	6.76		x 10	--	--
	x 3/4	1.07	.61		x 2 1/2	23.10	7.58		x 12	--	--
1 1/4	x 1/2	1.69	.67	5	x 3	23.63	8.07	16	x 8	--	--
	x 3/4	1.73	.73		x 2	35.07	12.03		x 10	--	--
1 1/2	x 1	1.77	.82	6	x 2 1/2	35.48	13.16	18	x 12	--	--
	x 1/2	2.67	.95		x 3	35.90	14.19		x 14	--	--
2	x 3/4	2.71	.99	8	x 4	37.57	15.12	20	x 10	--	--
	x 1	2.77	1.03		x 2 1/2	41.83	18.06		x 12	--	--
2 1/2	x 1 1/4	2.83	1.12	10	x 3	42.33	20.17	24	x 14	--	--
	x 3/4	4.67	1.74		x 4	43.82	21.81		x 16	--	--
3	x 1	4.73	1.85	12	x 5	44.82	22.89	28	x 10	--	--
	x 1 1/4	4.84	1.99		x 4	96.30	36.85		x 12	--	--
3 1/2	x 1 1/2	4.95	2.04	14	x 5	98.50	38.50	32	x 14	--	--
	x 1	7.97	2.59		x 6	101.00	40.30		x 16	--	--
4	x 1 1/4	8.06	2.67	16	x 4	210.00	62.30	36	x 18	--	--
	x 1 1/2	8.25	2.79		x 5	212.00	70.60		x 12	--	--
4 1/2	x 2	8.44	3.05	18	x 6	217.00	73.30	40	x 14	--	--
	x 1 1/4	12.16	3.63		x 8	222.00	77.10		x 16	--	--
5	x 1 1/2	12.30	3.85	20	x 5	411.00	112.00	44	x 18	--	--
	x 2	12.59	4.13		x 6	416.00	116.00		x 20	--	--
6	x 2 1/2	12.88	4.75	22	x 8	426.00	120.00	48			
				24	x 10	435.00	124.00	52			

Dimension Tolerances

Nominal Pipe Size	All Fittings			Wall Thickness	90° and 45° Elbows Tees	Caps
	Outside Diameter at Bevel		Inside Diameter at End		Center-to-End	Overall Length
	Schedules 5S and 10S Tube O.D.	Schedules Heavier than Sch. 10S				
1/2-1 1/2	+ 1/64	+ 1/16	± 1/32	Not less than 87 1/2% of nominal thickness	± 1/16	± 1/8
	- 1/32	- 1/32				
2-2 1/2	± 1/32	+ 1/16	± 1/32		± 1/16	± 1/8
		- 1/32				
3-3 1/2	± 1/32	± 1/16	± 1/16		± 1/16	± 1/8
4	± 1/32	± 1/16	± 1/16		± 1/16	± 1/8
5-8	- 1/16	+ 3/32	± 1/16		± 1/16	± 1/4
	- 1/32	- 1/16				
10-12	+ 3/32	+ 5/32	± 1/8		± 3/32	± 1/4
	- 1/32	- 1/8				
14-18	+ 3/32	+ 5/32	± 1/8	± 3/32	± 1/4	
	- 1/32	- 1/8				
20-24	+ 1/8	+ 1/4	± 3/16	± 3/32	± 1/4	
	- 1/32	- 3/16				

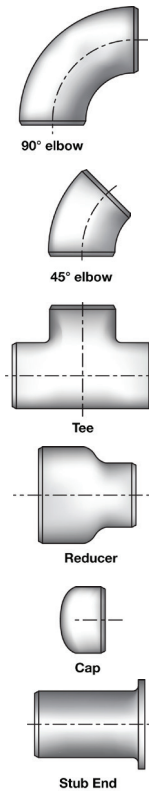

Nominal Pipe Size	180° Returns			Reducers Lap Joint Stub Ends	Lap Joint Stub Ends			
	Center-to-Center	Back-to-Face	Alignment of Ends	Overall Length	Outside Diameter of Lap	Thickness of Lap	Fillet Radius of Lap	Outside Diameter of Barrel
1/2-1 1/2	± 1/4	± 1/4	± 1/32	± 1/16	+ 0	+ 1/16	+ 0	Tolerances assure slip fit into Lap Joint Flange of minimum permissible inside diameter
					- 1/32	- 0	- 1/32	
2-2 1/2	± 1/4	± 1/4	± 1/32	± 1/16	+ 0	+ 1/16	+ 0	
					- 1/32	- 0	- 1/32	
3-3 1/2	± 1/4	± 1/4	± 1/32	± 1/16	+ 0	+ 1/16	+ 0	
					- 1/32	- 0	- 1/32	
4	± 1/4	± 1/4	± 1/32	± 1/16	+ 0	+ 1/16	+ 0	
					- 1/32	- 0	- 1/16	
5-8	± 1/4	± 1/4	± 1/32	± 1/16	+ 0	+ 1/16	+ 0	
					- 1/32	- 0	- 1/16	
10-12	± 3/8	± 1/4	± 1/16	± 3/32	+ 0	+ 1/16	+ 0	
					- 1/16	- 0	- 1/16	
14-18	± 3/8	± 1/4	± 1/16	± 3/32	+ 0	+ 1/16	+ 0	
					- 1/16	- 0	- 1/16	
20-24	± 3/8	± 1/4	± 1/16	± 3/32	+ 0	+ 1/16	+ 0	
					- 1/16	- 0	- 1/16	

Toll Free: 800 551 8392